

**FEATURES**

- ◆ Input voltage: 3.6V to 18V.
- ◆ Output voltage: 0.8V to VCC.
- ◆ BM1513 is 2A ; BM1513A is 3A
- ◆ Oscillation frequency: 400KHz
- ◆ Soft-start, Current limit, Enable function
- ◆ Thermal Shutdown function
- ◆ Built-in internal SW P-channel MOS
- ◆ replace AP151x series
- ◆ SOP-8L Pb-Free Package.

**APPLICATIONS**

- ◆ portable DVD
- ◆ LCD Monitor
- ◆ Graphic Card
- ◆ DVD-Video Player
- ◆ Telecom Equipment
- ◆ ADSL Modem
- ◆ Printer and other Peripheral Equipment
- ◆ Microprocessor core supply
- ◆ Networking power supply

**GENERAL DESCRIPTION**

BM1513/A consists of step-down switching regulator with PWM control. These devices include a reference voltage source, oscillation circuit, error amplifier, internal PMOS and etc.

BM1513/A provides low-ripple power, high efficiency and excellent transient characteristics. The PWM control circuit is able to vary the duty ratio linearly from 0 up to 100%. This converter also contains an error amplifier circuit as well as a soft-start circuit that prevents overshoot at startup. An enable function, an over current protect function and a short circuit protect function are built inside, and when OCP or SCP happens, the operation frequency will be reduced from 400KHz to 60KHz. Also, an internal compensation block is built in to minimize external component count.

These ICs can function as step-down switching regulators. They serve as ideal power supply units for portable devices when coupled with the SOP-8L mini-package, providing such outstanding features as low current consumption. Since this converter can accommodate an input voltage of up to 18V, it is also ideal when operating via an AC adapter.

**PIN ASSIGNMENTS**

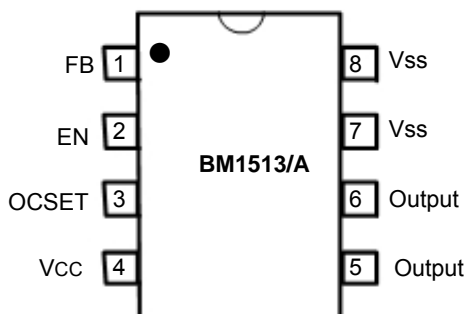

**PIN DESCRIPTIONS**

Name	Pin	Description
FB	1	Feedback pin.
EN	2	Power-off pin H: Normal operation (Step-down operation) L: Step-down operation stopped (All circuits deactivated)
OCSET	3	Add an external resistor to set max output current.
Vcc	4	IC power supply pin
Output	5 · 6	Switch Pin. Connect external inductor/diode here. Minimize trace area at this pin to reduce EMI.
Vss	7 · 8	GND Pin

**Ordering Information**

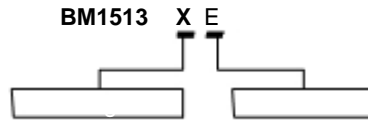

A: 3A ; Non-A means: 2A      E means engineer, Non E means normal.

**Block Diagram**

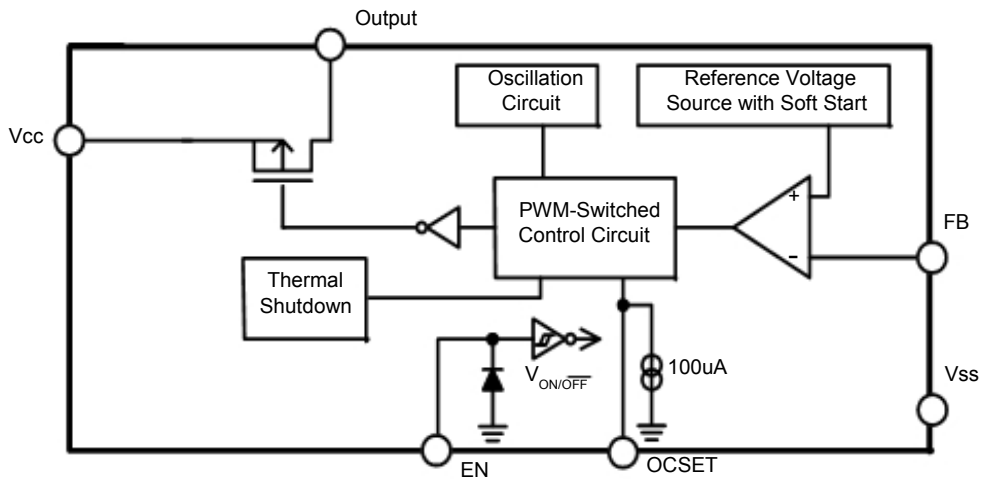

**Absolute Maximum Ratings**

Symbol	Parameter	Rating	Unit
$V_{CC}^{*1}$	$V_{CC}$ pin voltage	$V_{SS} - 0.3$ to $V_{SS} + 20$	V
$V_{FB}$	Feedback pin voltage	$V_{SS} - 0.3$ to $V_{CC}$	V
$V_{ON/OFF}^{*1}$	ON/OFF pin voltage	$V_{SS} - 0.3$ to $V_{IN} + 0.3$	V
$V_{OUTPUT}$	Switch pin voltage	$V_{SS} - 0.3$ to $V_{IN} + 0.3$	V
$P_D$	Power dissipation	Internally limited	mW
$T_{OPR}$	Operating temperature range	-20 to +125	$^{\circ}C$
$T_{STG}$	Storage temperature range	-40 to +150	$^{\circ}C$

Caution: The absolute maximum ratings are rated values exceeding which the product could suffer physical damage. These values must therefore not be exceeded under any conditions.

**Electrical Characteristics** ( $V_{IN} = 12V$ ,  $T_a=25^{\circ}C$ , unless otherwise specified)

Symbol	Parameter	Conditions	Min.	Typ.	Max.	Unit
$V_{FB}$	Feedback Voltage	--	0.784	0.8	0.816	V
$V_{IN}$	Input voltage	--	3.6	--	18	V
$I_{SW}$	Switch Current (1513/A)	--	2A/3.0	--	--	A
$I_{SSS}$	Current consumption during power off	$V_{ON/OFF} = 0V$	--	10	--	$\mu A$
$\frac{\Delta V_{OUT}}{V_{OUT}}$	Line regulation	$V_{IN} = 3.6V \sim 18V$	--	0.6	1	%
$\frac{\Delta V_{OUT}}{V_{OUT}}$	Load regulation	$I_{OUT} = 0$ to 2A	--	0.2	0.5	%
$f_{OSC}$	Oscillation frequency	Measure waveform at SW pin	360	400	440	KHz
$f_{OSC1}$	Frequency of current limit or short circuit protect	Measure waveform at SW pin	--	60	--	KHz
$V_{SH}$	EN pin input voltage	Evaluate oscillation at SW pin	2.0	--	--	V
$V_{SL}$		Evaluate oscillation stop at SW pin	--	--	0.8	
$I_{SH}$	EN pin input leakage current	--	-10	--	10	$\mu A$
$I_{SL}$		--	-10	--	10	
$I_{OCSET}$	OCSET pin bias current	--	90	100	110	$\mu A$
$T_{SS}$	Soft-Start time	--	0.3	2	5	ms
$R_{DSON}$	Internal MOSFET Rdson	--	--	100	150	m $\Omega$
EFFI	Efficiency	$V_{IN} = 12V$ , $V_{OUT} = 5V$ $I_{OUT} = 2A$	--	92	--	%

**Typical Application Circuit**

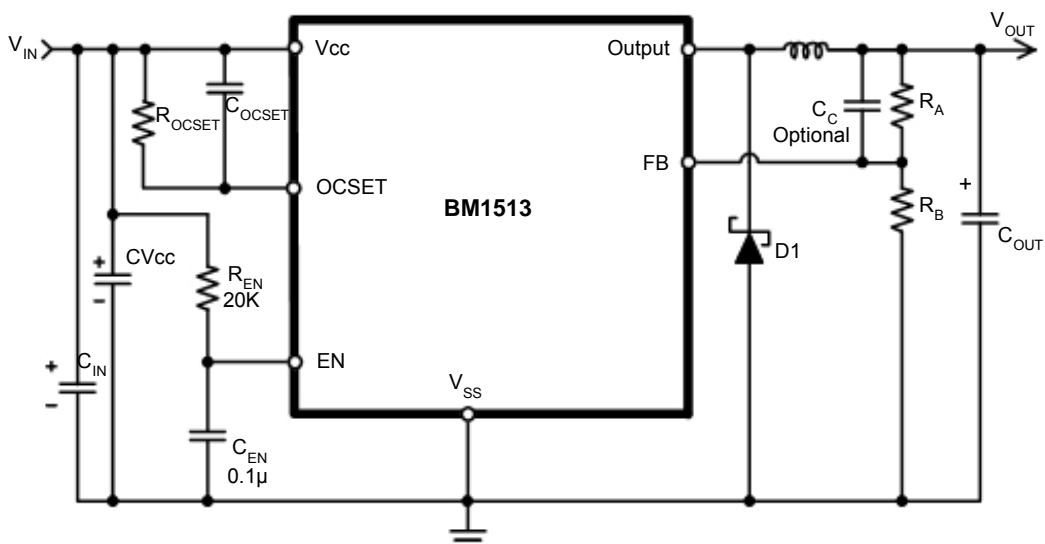

**Note:**  $V_{OUT} = V_{FB} \times (1 + R_A/R_B)$   
 $R_B = 1K \sim 10K$  ohm

**Typical Performance Characteristics**

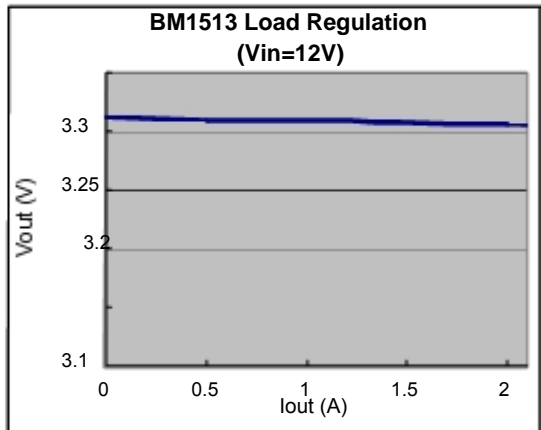
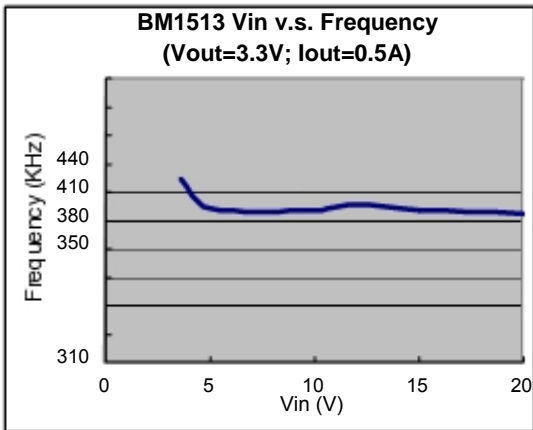
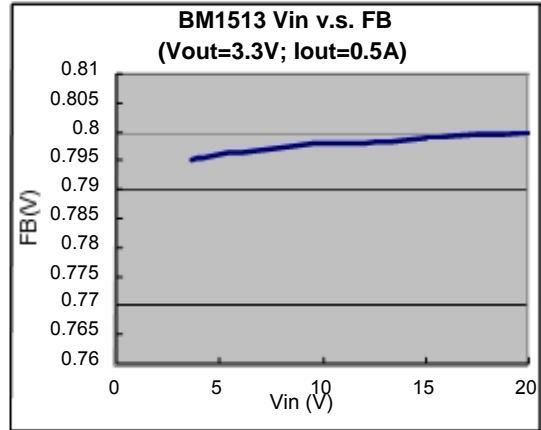
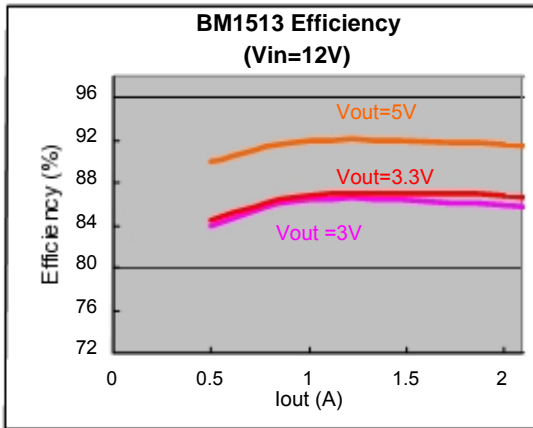

**Typical Performance Characteristics (Continued)**

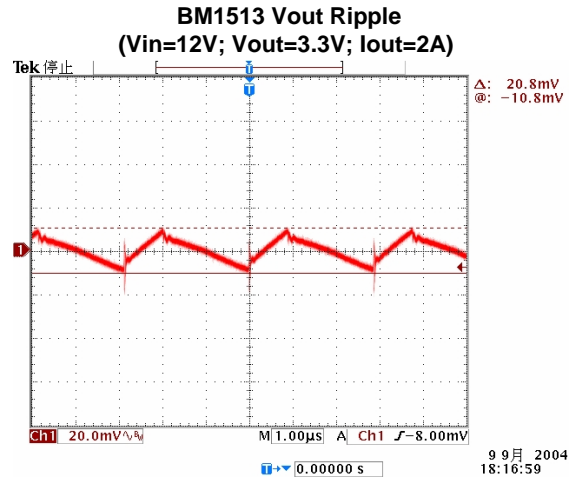
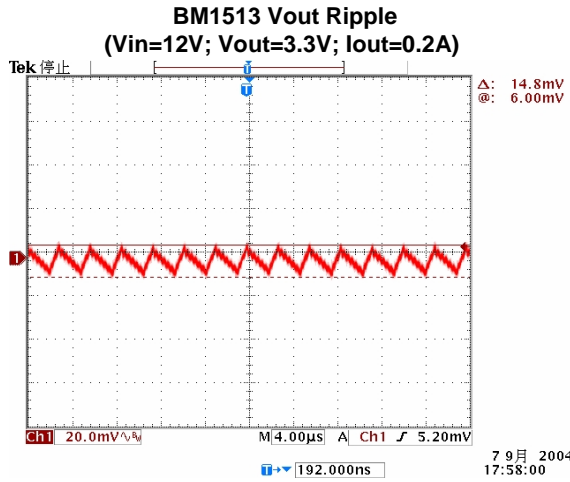

**Test Circuit**

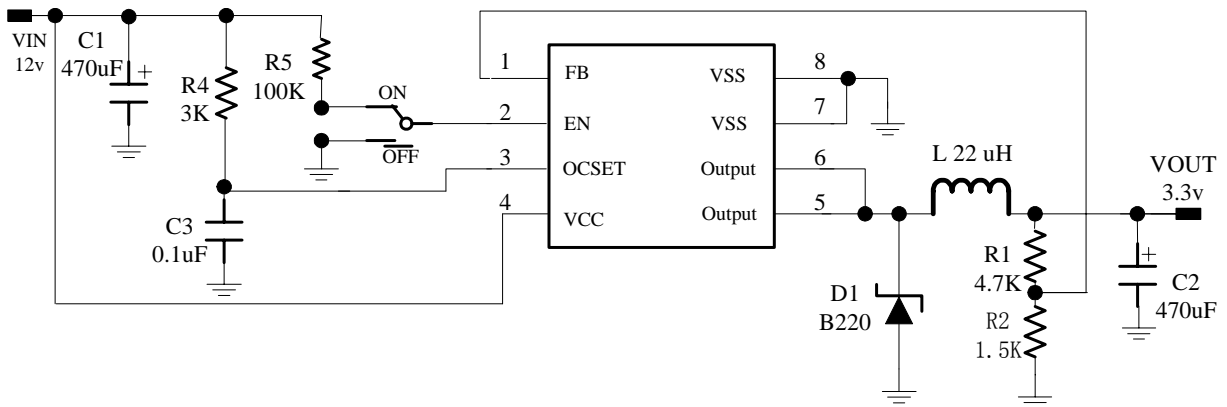
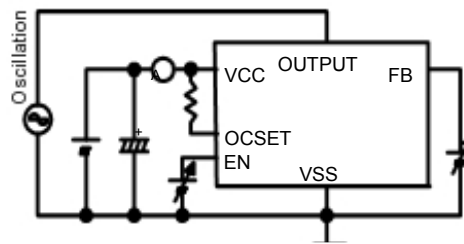
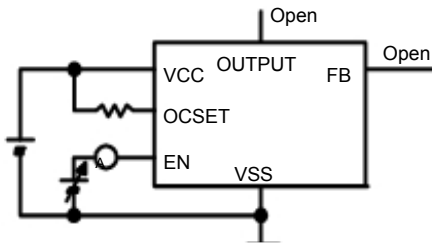

**PWM Control**

The BM1513/A consists of DC/DC converters that employ a pulse-width modulation (PWM) system. In converters of the BM1513/A, the pulse width varies in a range from 0 to 100, according to the load current, and yet ripple voltage produced by the switching can easily be removed through a filter because the switching frequency remains constant. Therefore, these converters provide a low-ripple power over broad ranges of input voltage and load current.

**Under Voltage Lockout**

The under voltage lockout circuit of the BM1513/A assures that the high-side MOSFET driver outputs remain in the off state whenever the supply voltage drops below set parameters. Lockout occurs if V<sub>CC</sub> falls below 3.3V. Normal operation resumes once V<sub>CC</sub> rises above 3.5V.

**Output Voltage Definition**

The output voltage is programmed by selection of the divider R1 and R2. Designer should use resistors R1 and R2 with ±1% tolerance in order to obtain best accuracy of output voltage. The output voltage can be calculated from the following formula.

$$V_{out} = 0.8 \times (1 + R1 / R2)$$

Select a value for R2 between 0.5KΩ and 10KΩ. The lower resistor values minimize noise pickup in the sensitive feedback pin.

Recommended resistance value list below:

	V <sub>o</sub> = 3.3V	V <sub>o</sub> = 5.0V
R1	4.7K	6.8K
R2	1.5K	1.3K

**Max. Current Limiting**

The current limit threshold is setting by connecting an external resistor from V<sub>CC</sub> supply to OCSET. The voltage drop across this resistor is due to the 100uA internal sink sets the voltage at the pin. When the PWM voltage is less than the voltage at OCSET, an over-current condition occurs.

Select a value for R<sub>OCSET</sub> to set the current limit level by using this formula:

$$I_{LOAD} = (I_{OCSET} \times R_{OCSET}) / R_{DSON}$$

In which the R<sub>DSON</sub> =100 mΩ、I<sub>OCSET</sub> =100uA, if the R<sub>OCSET</sub> =3K then the I<sub>LOAD</sub> have 3A maximum transient current.

**Note:**

BM1513A is fully same as BM1513 , only bigger current output , BM1513A can replace BM1513 without change anything in external.

**Package Information**

Package Type: SOP-8L

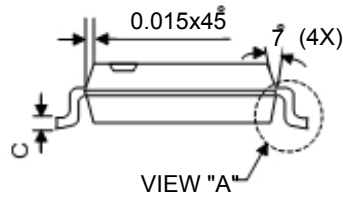
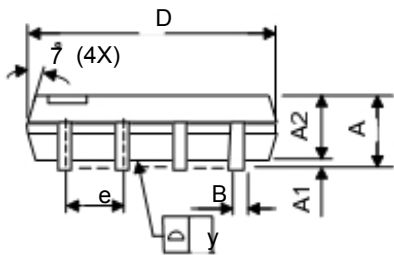
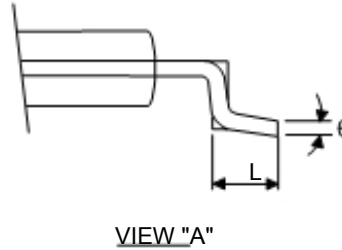
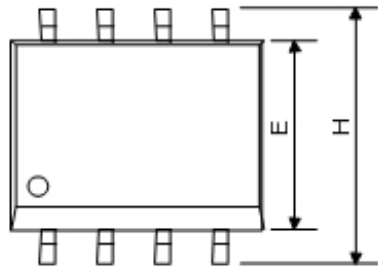

Symbol	Dimensions In Millimeters			Dimensions In Inches		
	Min.	Nom.	Max.	Min.	Nom.	Max.
A	1.40	1.60	1.75	0.055	0.063	0.069
A1	0.10	-	0.25	0.040	-	0.100
A2	1.30	1.45	1.50	0.051	0.057	0.059
B	0.33	0.41	0.51	0.013	0.016	0.020
C	0.19	0.20	0.25	0.0075	0.008	0.010
D	4.80	5.05	5.30	0.189	0.199	0.209
E	3.70	3.90	4.10	0.146	0.154	0.161
e	-	1.27	-	-	0.050	-
H	5.79	5.99	6.20	0.228	0.236	0.244
L	0.38	0.71	1.27	0.015	0.028	0.050
y	-	-	0.10	-	-	0.004
θ	0°	-	8°	0°	-	8°