

White LED Step-Up Converter

BM0246A is a step-up DC/DC converter specifically designed to drive white LED with a constant current. It can drive two, three, or four LEDs. It switches at 1.4MHz and use tiny external components. The output capacitor can be as small as 0.22uF, which can save space and cost versus alternative solutions. Feedback voltage is as low as 105mV. Built-in OverVoltage function.

- OverVoltage Function
- Fast 1.4MHz Switching Frequency
- Requires Only 0.22uF Output Capacitor
- Inherently Matched LED Current
- High Efficiency: 90% Typical
- 2.5V to 16V V_{IN} ranges
- Drives Up to Four series LEDs with a Li-Ion cell
- PIN TO PIN with **RT9271** and **AIC1896, D246**
- SOT-26 Package

Absolute maximum ratings

Parameter	symbol	value	unit
Supply Voltage	V_{IN}	15	V
Feedback Voltage	FB	10	V
Switch Voltage	SW	30	V
CE Voltage	V_{CE}	10	V
Operating temperature range	T_{opr}	-25 to +85	°C
Storage temperature range	R_{stg}	-55 to +150	°C
Junction temperature	T_j	125	°C

Pin name

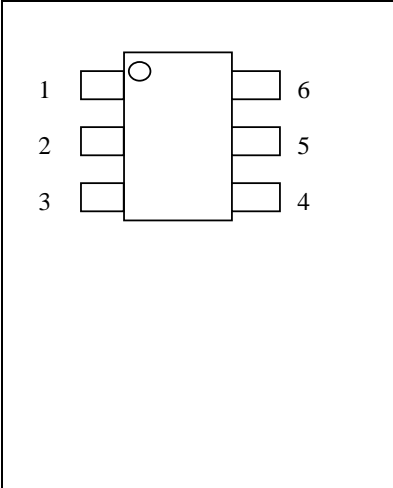
	Description	Symbol	Description	Symbol
	1: Switch	SW	6: Supply Voltage	V_{IN}
	2: GND	GND	5: Over Voltage	OVP
	3: Feedback	FB	4: Start-Up	CE

BOOST IC (LED DRIVER)

BM0246A

Block Diagram

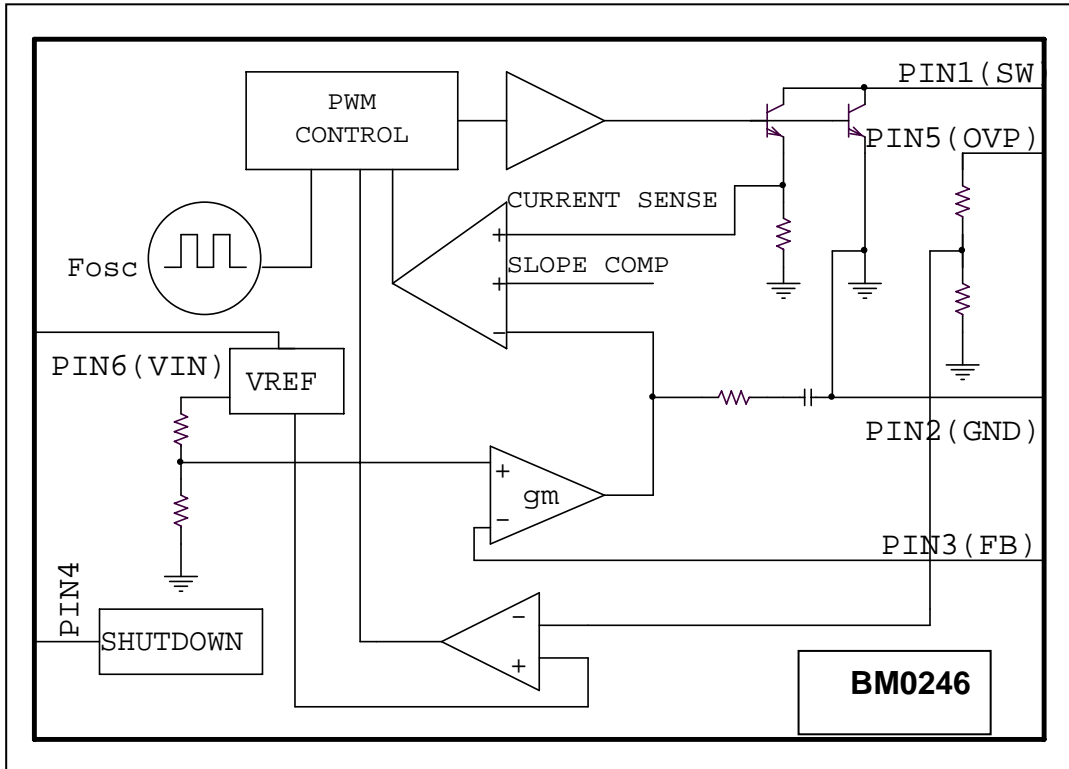

BOOST IC (LED DRIVER)

BM0246A

Electrical Characteristics

T_{amb} = 25°C, V_{IN}=3V, V_{CE}=3V, unless otherwise specified.

Parameter	Test Conditions / Pins	Min	Type	Max	Unit
Minimum Operating Voltage		2.5			V
Maximum Operating Voltage				10	V
Feedback Voltage	I _{SW} =100mA, Duty Cycle=66%	104	115	126	mV
FB Pin Bias Current		50	100	200	nA
Supply Current	V _{CE} =0V		1.9 0.1	2.5 1	mA uA
Switching Frequency		0.8	1.0	1.2	MHz
Maximum Duty Cycle		85	90		%
OVP Protection			21		V
Switch Current Limit			320		mA
Switch V _{CESAT}	I _{SW} =250mA		350		mV
Switch Leakage Current	V _{SW} =5V		0.01	5	uA
CE Voltage High		1.5			V
CE Voltage Low				0.4	V
CE Pin Bias Current			65		uA

Typical Application

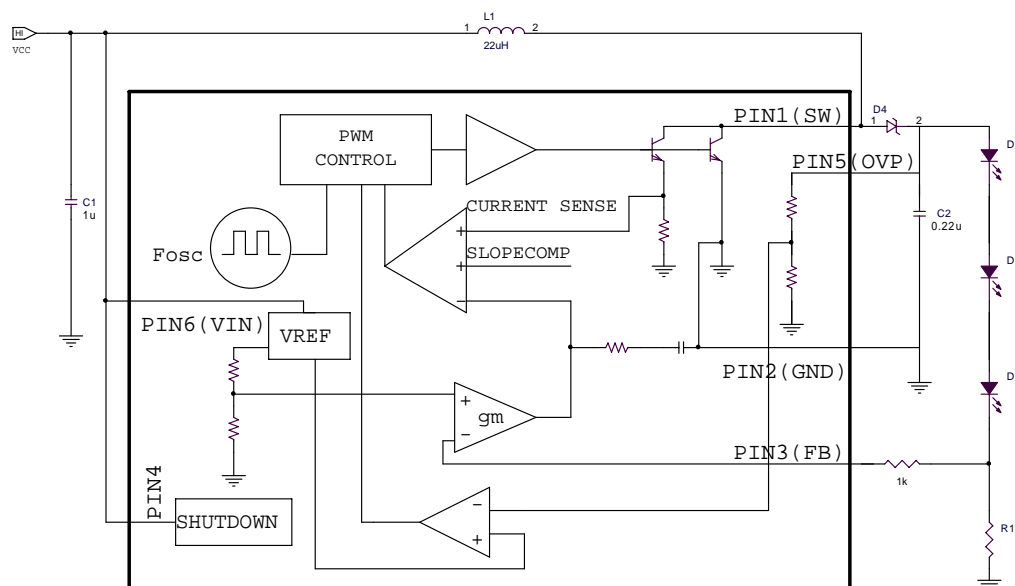

BOOST IC (LED DRIVER)

BM0246A

Analog Voltage Light Control

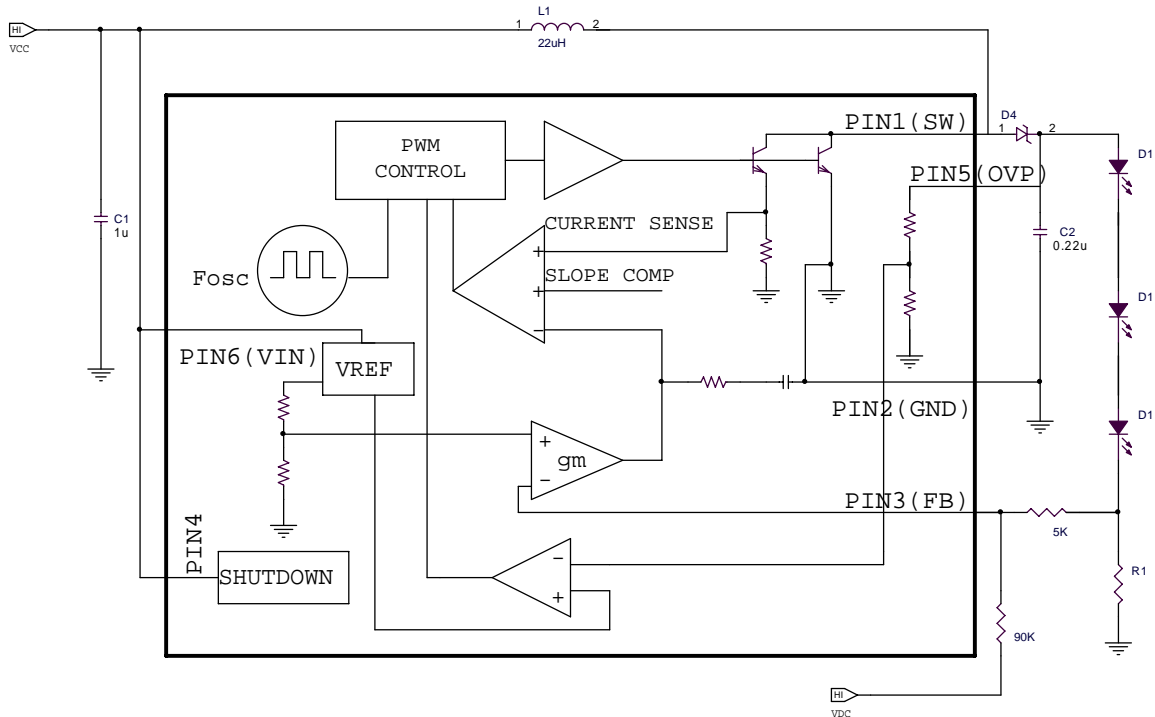

Logic Voltage Light Control

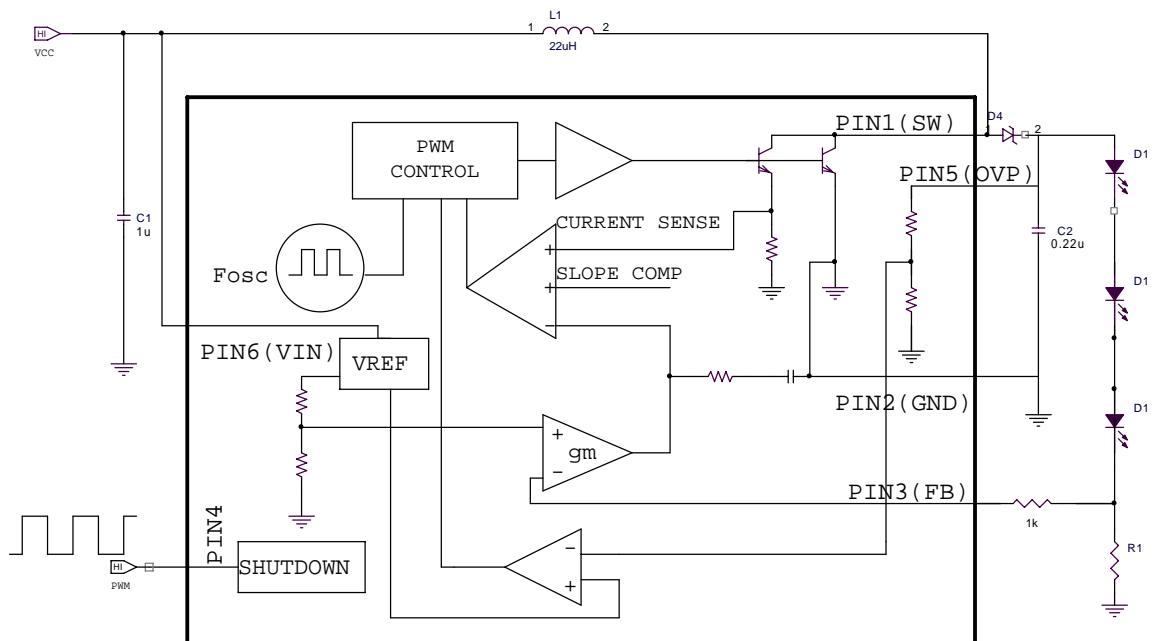

Figure

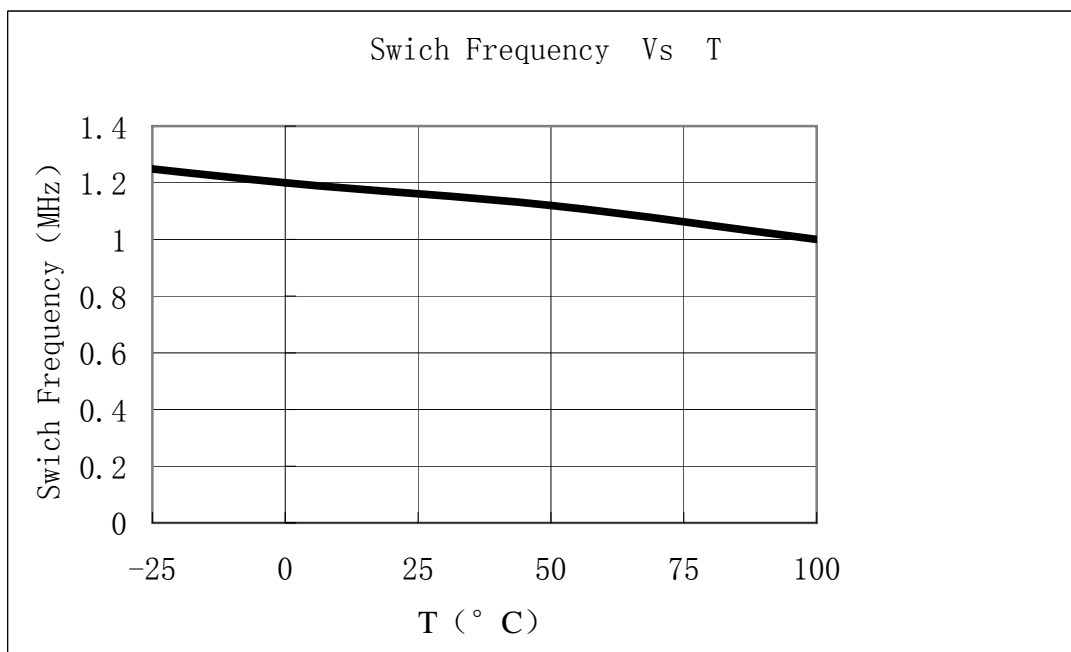
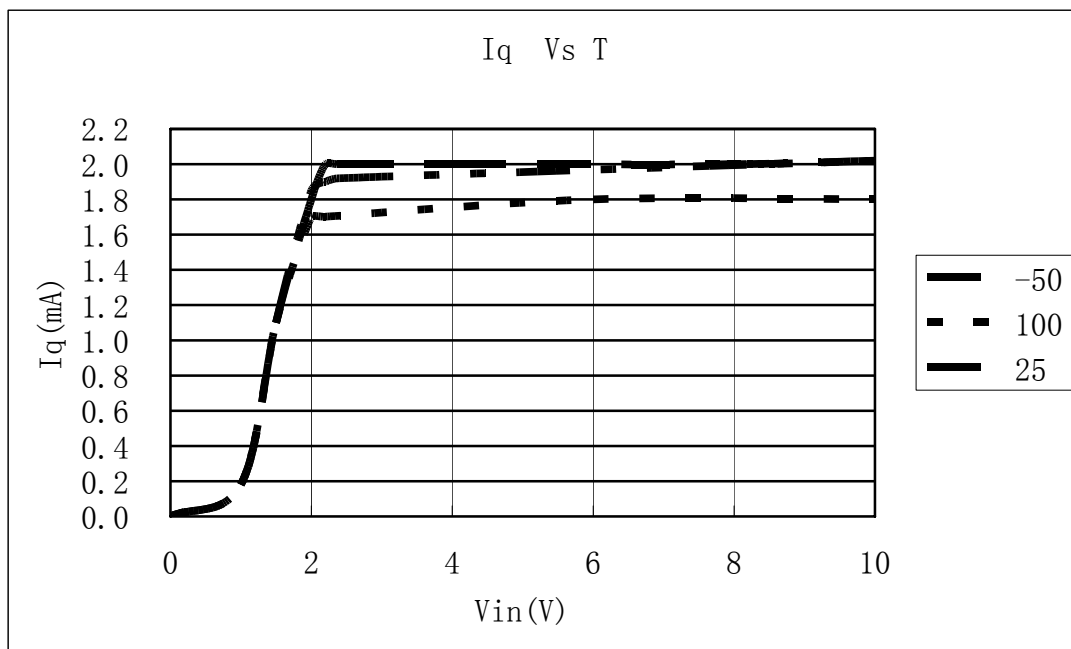

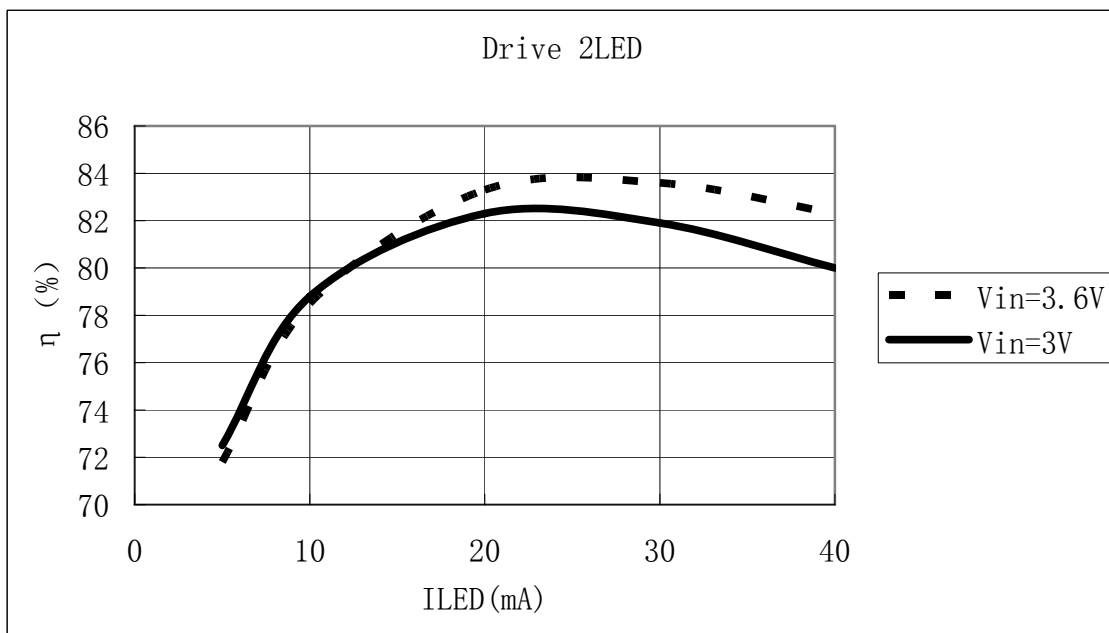
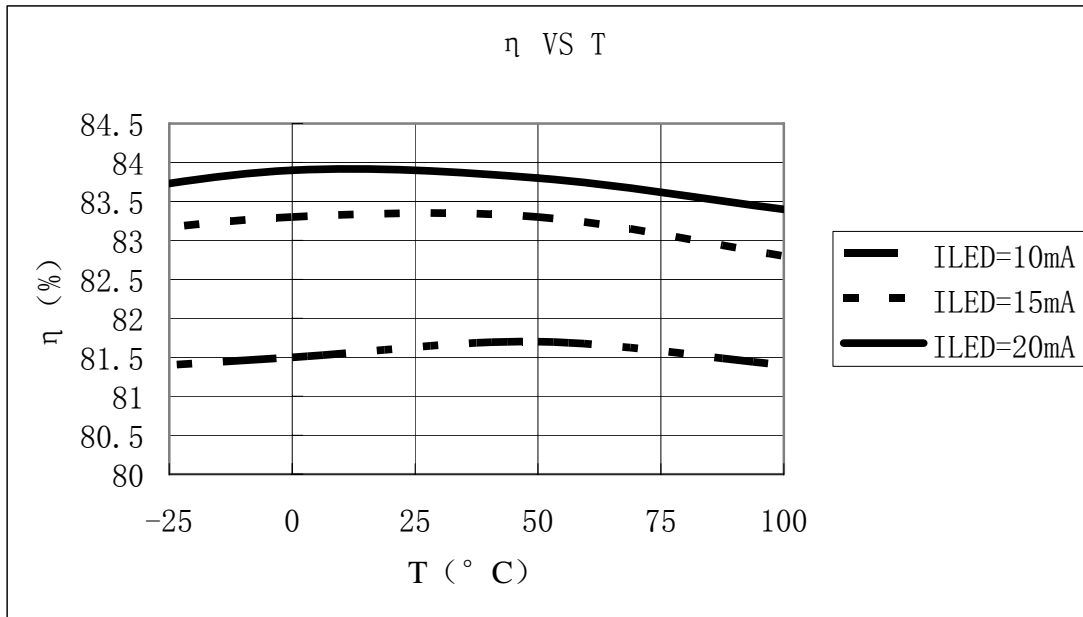

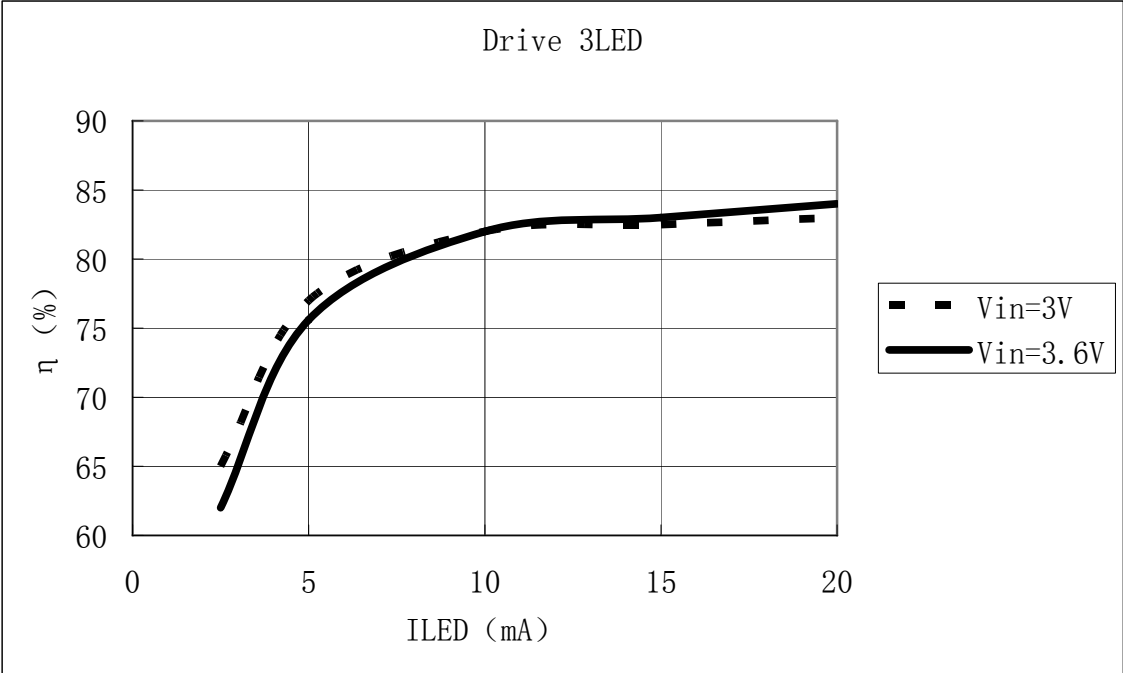

BOOST IC (LED DRIVER)

BM0246A

SOT-26 Diagram

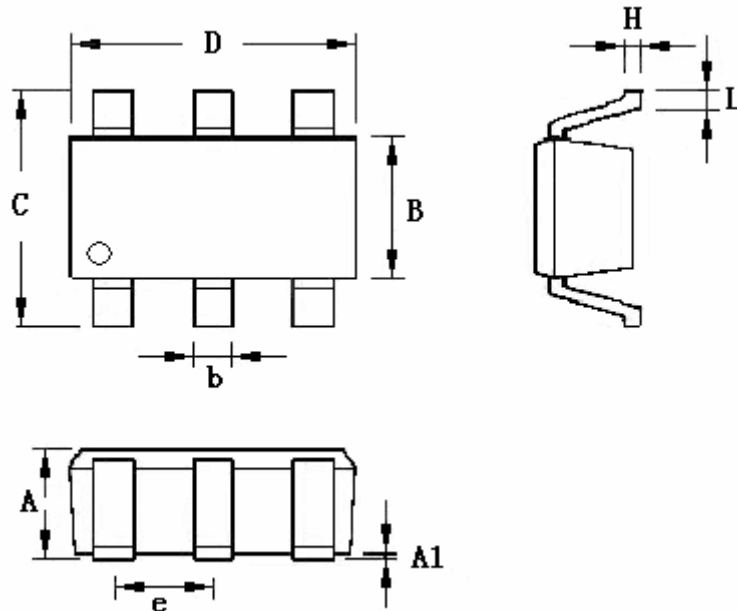

Symbol	Dimension(in mm)		Dimension(in Inch)	
	min	max	min	max
A	0.787	1.450	0.031	0.057
A1		0.152		0.006
B	1.397	1.803	0.055	0.071
b	0.250	0.559	0.010	0.022
C	2.591	2.997	0.102	0.118
D	2.692	3.099	0.106	0.122
E	0.838	1.041	0.033	0.041
H	0.080	0.254	0.003	0.010
L	0.300	0.610	0.012	0.024